



**MODEL# : UIM-155**

# **WHYNTER BUILT-IN ICE MAKER INSTRUCTION MANUAL**



## PARTS OVERVIEW

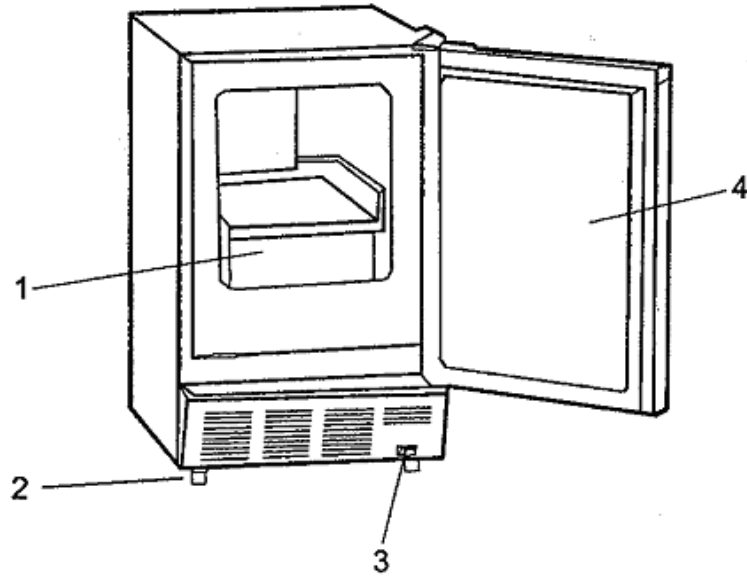

1. ICE BUCKET
2. FOOT
3. ON/OFF SWITCH
4. DOOR

**⚡WARNING⚡**

TO REDUCE THE RISK OF FIRE, ELECTRICAL SHOCK, OR INJURY WHEN USING YOUR ICE MAKER, FOLLOW THESE BASIC PRECAUTIONS:

- READ ALL INSTRUCTIONS BEFORE USING THE ICE MAKER.
- **WARNING:** RISK OF DANGER TO SMALL CHILDREN AND SMALL ANIMALS. ENTRAPMENT AND SUFFOCATION DANGER IF NOT PROPERLY SECURED. DISPOSED OR ABANDONED APPLIANCES ARE STILL DANGEROUS
- **BEFORE YOU DISPOSE OF YOUR ICE MAKER:** REMOVE THE DOOR AND LEAVE THE SHELVES IN PLACE TO PREVENT CHILDREN FROM CLIMBING INTO THE UNIT.
- NEVER ALLOW CHILDREN TO OPERATE, PLAY WITH, OR CRAWL INTO THE APPLIANCE.
- NEVER CLEAN ICE MAKER PARTS WITH FLAMMABLE FLUIDS. THE FUMES CAN CREATE A FIRE HAZARD.
- DO NOT STORE OR USE GASOLINE OR ANY OTHER FLAMMABLE VAPORS AND LIQUIDS IN THE VICINITY OF THIS OR ANY OTHER APPLIANCE. THE FUMES CAN CREATE A FIRE HAZARD.

**-SAVE THESE INSTRUCTIONS-**

## INSTALLATION INSTRUCTIONS

### ➤ **BEFORE USING YOUR ICE MAKER**

- REMOVE THE EXTERIOR AND INTERIOR PACKAGING MATERIAL.
- CHECK TO BE SURE YOU HAVE ALL OF THE FOLLOWING PARTS:
  - 1 ICE BUCKET
  - 1 PLASTIC SCOOP
  - 25 FT. HOSE
  - 1 INSTRUCTION MANUAL
- BEFORE CONNECTING THE ICE MAKER TO THE POWER SOURCE, LET IT STAND UPRIGHT FOR APPROXIMATELY 4 HOURS. THIS WILL REDUCE THE POSSIBILITY OF A MALFUNCTION IN THE COOLING SYSTEM FROM HANDLING DURING TRANSPORTATION.
- CLEAN THE INTERIOR SURFACE WITH LUKEWARM WATER USING A SOFT CLOTH.

### ➤ **INSTALLATION OF YOUR ICE MAKER**

- THIS APPLIANCE IS DESIGNED TO BE RECESSED OR BUILT-IN (FULLY RECESSED).
- PLACE YOUR ICE MAKER ON A HARD AND LEVEL FLOOR THAT IS STRONG ENOUGH TO SUPPORT THE ICE MAKER WHEN IT IS FULLY LOADED. REMEMBER THAT THE UNIT WILL BE SIGNIFICANTLY HEAVIER ONCE IT IS FULLY LOADED. TO LEVEL YOUR ICE MAKER, ADJUST THE LEG AT THE FRONT OF THE ICE MAKER.
- PLACE THE ICE MAKER AWAY FROM DIRECT SUNLIGHT AND SOURCES OF HEAT (STOVE, HEATER, RADIATOR, ETC.). DIRECT SUNLIGHT MAY AFFECT THE ACRYLIC COATING AND HEAT SOURCES MAY INCREASE ELECTRICAL CONSUMPTION. EXTREME COLD AMBIENT TEMPERATURES MAY ALSO CAUSE THE ICE MAKER NOT TO PERFORM PROPERLY.
- AVOID LOCATING THE ICE MAKER IN DAMP AND HUMID AREAS. TOO MUCH HUMIDITY IN THE AIR WILL CAUSE FROST TO FORM QUICKLY ON THE EVAPORATOR REQUIRING MORE FREQUENT DEFROSTING OF THE ICE MAKER.
- PLUG THE ICE MAKER INTO AN EXCLUSIVE PROPERLY INSTALLED-GROUNDED WALL OUTLET. DO NOT UNDER ANY CIRCUMSTANCES CUT OR REMOVE THE THIRD (GROUND) PRONG FROM THE POWER CORD. ANY QUESTIONS CONCERNING POWER AND OR GROUNDING SHOULD BE DIRECTED TOWARD A QUALIFIED ELECTRICIAN.

### ➤ **ELECTRICAL CONNECTION**

#### **⚡ WARNING ⚡**

IMPROPER USE OF THE GROUNDED PLUG CAN RESULT IN THE RISK OF ELECTRICAL SHOCK. IF THE POWER CORD IS DAMAGED, DO NOT ATTEMPT ANY REPAIRS. ORDER A REPLACEMENT FROM YOUR WHYNTER RETAILER AND HAVE A QUALIFIED ELECTRICIAN REPLACE THE POWER CORD

- THIS ICE MAKER SHOULD BE PROPERLY GROUNDED FOR YOUR SAFETY. THE POWER CORD OF THIS ICE MAKER IS EQUIPPED WITH A THREE-PRONG PLUG WHICH IS USED WITH STANDARD THREE PRONG WALL OUTLETS TO MINIMIZE THE POSSIBILITY OF ELECTRICAL MALFUNCTION.
- DO NOT UNDER ANY CIRCUMSTANCES CUT OR REMOVE THE THIRD GROUND PRONG FROM THE POWER CORD SUPPLIED.
- DO NOT USE AN EXTENSION CORD TO CONNECT POWER TO THE UNIT.
- NEVER USE A TWO-PRONG GROUNDING ADAPTER.
- WHERE A TWO-PRONG WALL RECEPTACLE IS ENCOUNTERED, CONTACT A QUALIFIED ELECTRICIAN TO HAVE IT REPLACED WITH A 3-PRONG RECEPTACLE IN ACCORDANCE WITH APPLICABLE ELECTRICAL CODES.
- THIS ICE MAKER REQUIRES A STANDARD 115/120 VOLTS A.C./60HZ ELECTRICAL OUTLET WITH THREE-PRONG GROUND.
- THE CORD SHOULD BE SECURED BEHIND THE ICE MAKER AND NOT LEFT EXPOSED OR DANGLING TO PREVENT ACCIDENTAL INJURY.

➤ **EXTENSION CORD**

IT IS STRONGLY RECOMMENDED THAT YOU DO NOT USE AN EXTENSION CORD WITH THIS APPLIANCE. HOWEVER, IF YOU MUST USE AN EXTENSION CORD IT IS ABSOLUTELY NECESSARY THAT IT BE A UL/CUL-LISTED, 3-WIRE GROUNDING TYPE APPLIANCE EXTENSION CORD HAVING A GROUNDING TYPE PLUG AND OUTLET AND THAT THE ELECTRICAL RATING OF THE CORD BE 115 VOLTS AND AT LEAST 10 AMPERES.

➤ **CONNECTING THE WATER SUPPLY**

**⚡ WARNING ⚡**  
**IMPROPER WATER LINE CONNECTION MAY RESULT IN FLOODING**  
**YOU MUST USE A LICENSED PLUMBER AND**  
**REVIEW STATE AND LOCAL PLUMBING CODES BEFORE INSTALLATION**

- ALL THE REQUIRED OR CUSTOMIZED HARDWARE IS NOT PROVIDED FOR INSTALLATION SO IT IS NECESSARY TO HIRE A PROFESSIONAL LICENSED PLUMBER TO COMPLETE THE INSTALLATION.
- CONNECT TUBING (SUPPLIED WITH UNIT) TO THE NEAREST COLD WATER SOURCE. CONNECT SUFFICIENT TUBING TO THE UNIT TO ALLOW THE APPLIANCE TO BE MOVED FREELY FOR CLEANING AND SERVICE. ALSO, MAKE SURE THAT THE TUBING IS NOT CRIMPED OR DAMAGED DURING TRANSPORTATION.
- POSITION UNIT TO ALLOW FREE AIRFLOW THROUGH THE FRONT GRILL (SEE SKETCH 1).

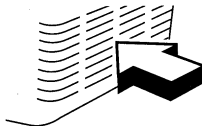

SKETCH 1

- WIPE INSIDE OF UNIT AND ICE BUCKET WITH A DAMP CLOTH.

## **OPERATING YOUR ICE MAKER**

➤ **INITIAL START-UP OPERATION**

1. PLUG THE APPLIANCE INTO A 115/120V POLARIZED AND GROUNDED WALL ELECTRICAL OUTLET.
2. PLACE THE ON-OFF SWITCH IN THE "ON" POSITION.
3. MAKE SURE THE WATER SUPPLY IS ON. AS SOON AS THE INNER MECHANISM REACHES THE PROPER TEMPERATURE, THE ICEMAKER MECHANISM WILL FILL THE MOLD WITH WATER.
4. THE FIRST CUBES MAY BE SMALL BECAUSE OF AIR IN THE WATER LINE. LATER CUBES WILL BE OF STANDARD CRESCENT TYPE SIZE.
5. APPROXIMATE TIME FOR THE FIRST CYCLE IS BETWEEN 30-40 MINUTES.
6. EACH CYCLE APPROXIMATELY WILL TAKE 5 OZs OF WATER SO YOU SHOULD HAVE A FULL TRAY, AFTER 11 HOURS.

**IMPORTANT: THROW AWAY ALL ICE CUBES MADE DURING THE FIRST 3 HOURS OF OPERATION.**

- WHEN THE ICE BUCKET IS FULL, THE ICE MAKING MECHANISM WILL AUTOMATICALLY SHUT OFF. WHEN ICE CUBES ARE MELTED, THE ICE MAKING MECHANISM WILL START AGAIN .
- ICE DELIVERY MAY BE INTERRUPTED BY RAISING THE METAL ARM INTO AN UPRIGHT POSITION (SEE SKETCH 2)
- IF THE ICEMAKER IS NOT USED REGULARLY, IT IS RECOMMENDED THAT THE ICE BUCKET BE EMPTIED PERIODICALLY TO INSURE FRESH ICE.

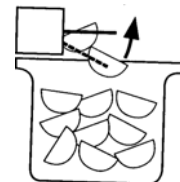

SKETCH 2

- SOMETIMES THE CUBES MAY APPEAR CLOUDY. THIS IS DUE TO THE RAPID FREEZING OF THE ICE CUBE. THIS IS TRAPPED AIR IN THE WATER AND DOES NOT AFFECT THE TASTE AND QUALITY OF THE ICE.
- THE FRONT GRILL SHOULD BE KEPT FREE OF DUST AND LINT TO ALLOW FREE AIRFLOW.
- THIS UNIT SHOULD BE DEFROSTED APPROXIMATELY EVERY 4-6 WEEKS OR WHEN FROST ON THE ICE MAKER WALLS IS EXCESSIVE OR ¼" THICK. TO DEFROST, TURN THE UNIT OFF, REMOVE CUBES AND KEEP DOOR OPEN AT LEAST TWO INCHES.

## **CARE AND MAINTENANCE**

### ➤ **CLEANING YOUR ICE MAKER**

- TURN THE SWITCH CONTROL TO "OFF", UNPLUG THE ICE MAKER AND REMOVE ICE BUCKET.
- WASH THE INSIDE WITH A WARM WATER AND BAKING SODA SOLUTION. THE SOLUTION SHOULD BE ABOUT 2 TABLESPOONS OF BAKING SODA TO A QUART OF WATER.
- WASH THE BUCKET WITH A MILD DETERGENT SOLUTION.
- THE OUTSIDE OF THE ICE MAKER SHOULD BE CLEANED WITH MILD DETERGENT AND WARM WATER.
- THE CONDENSER COILS SHOULD BE VACUUMED WHEN THEY ARE DUSTY OR DIRTY.



## **CAUTION**

**FAILURE TO UNPLUG THE ICE MAKER DURING MAINTENANCE COULD RESULT IN ELECTRICAL SHOCK OR PERSONAL INJURY.**

➤ **POWER FAILURE**

TYPICALLY MOST POWER OUTAGES LAST FOR NO LONGER THAN A FEW HOURS AND SHOULD NOT AFFECT THE TEMPERATURE OF YOUR ICE MAKER IF YOU MINIMIZE THE NUMBER OF TIMES THE DOOR IS OPENED. IF THE POWER IS GOING TO BE OFF FOR A LONGER PERIOD OF TIME, YOU NEED TO TAKE THE PROPER STEPS TO DISCONNECT YOUR APPLIANCE.

➤ **VACATION TIME/STORAGE**

1. SHUT OFF WATER SUPPLY AT THE MAIN WATER VALVE.
2. DISCONNECT THE WATER SUPPLY LINE FROM VALVE.
3. ALLOW UNIT TO RUN FOR AN HOUR OR TWO UNTIL ALL REMAINING ICE CUBES HAVE BEEN EJECTED.
4. DISCONNECT UNIT FROM MAIN POWER SOURCE.
5. DRY OUT EXCESS WATER FROM ICE MAKER ASSEMBLY
6. LEAVE THE DOOR AT LEAST TWO INCHES OPEN.

➤ **MOVING YOUR ICE MAKER**

- SECURELY TAPE DOWN ALL LOOSE ITEMS INSIDE YOUR ICE MAKER.
- TURN THE LEVELING SCREWS UP SECURELY TOWARDS THE BASE OF THE UNIT TO AVOID DAMAGE.
- TAPE THE DOOR SHUT.
- BE SURE THE ICE MAKER STAYS IN AN UPRIGHT POSITION DURING TRANSPORTATION.

➤ **ENERGY SAVING TIPS**

- THE ICE MAKER SHOULD BE SITUATED IN THE COOLEST AREA OF THE ROOM, AWAY FROM HEAT GENERATING APPLIANCES OR HEATING DUCTS, AND OUT OF THE DIRECT SUNLIGHT.

YOU CAN SOLVE MANY COMMON ICE MAKER PROBLEMS EASILY. TRY THE SUGGESTIONS BELOW TO SEE IF YOU CAN SOLVE THE PROBLEM BEFORE CONTACTING OUR SERVICE DEPARTMENT.

### TROUBLESHOOTING GUIDE

PROBLEM	POSSIBLE CAUSE
ICE MAKER DOES NOT OPERATE.	UNIT NOT PLUGGED IN. THE CIRCUIT BREAKER IS TRIPPED OR A BLOWN FUSE. THE ICE MAKER POWER SWITCH IS SET AT "OFF".
ICE MAKER DOES NOT PRODUCING ICE	AIRFLOW TO FRONT GRILL IS BLOCKED. THE ICE MAKER ARM IS SET TO THE OFF POSITION. WATER SUPPLY IS TURNED OFF. WATER LINE IS BLOCKED. ICE MAKER HAS EXCESSIVE FROST BUILD UP. ICE BUCKET IS FULL.
COMPRESSOR TURNS ON AND OFF FREQUENTLY.	THE ROOM TEMPERATURE IS WARMER THAN NORMAL. THE DOOR IS OPENED TOO OFTEN. THE DOOR IS NOT SECURELY CLOSED. THE DOOR GASKET DOES NOT SEAL PROPERLY. THE FRONT OF THE ICE MAKER DOES NOT HAVE ENOUGH CLEARANCES.
VIBRATIONS	CHECK TO ASSURE THAT THE ICE MAKER IS ON LEVEL AND HARD SURFACE. VOLTAGE IS NOT NORMAL.
THE ICE MAKER SEEMS TO MAKE TOO MUCH NOISE.	THE RATTLING NOISE MAY COME FROM THE FLOW OF THE REFRIGERANT, WHICH IS NORMAL. AS EACH CYCLE ENDS, YOU MAY HEAR GURGLING SOUNDS CAUSED BY THE FLOW OF REFRIGERANT IN YOUR ICE MAKER. CONTRACTION AND EXPANSION OF THE INSIDE WALLS MAY CAUSE POPPING AND CRACKLING NOISES. THE ICE MAKER IS NOT LEVEL.
THE DOOR WILL NOT CLOSE PROPERLY.	THE ICE MAKER IS NOT LEVEL. THE DOOR IS REVERSED AND NOT PROPERLY INSTALLED. THE DOOR GASKET OR SEAL IS DIRTY. THE BUCKET IS OUT OF POSITION.
ICE CUBES ARE MELTED TOGETHER	ICE MAKER DOOR IS OPENED TOO OFTEN.



# **ONE YEAR LIMITED WARRANTY**

This WHYNTER product is warranted, to the original owner within the 48 continental states, for one year from the date of purchase against defects in material and workmanship under normal use and service. When making a warranty claim, please have the original bill or invoice of purchase with purchase date available. Should your WHYNTER product prove defective within one year from the date of purchase, return the defective part or unit, freight prepaid (within two months of purchase; after two months to one year, customer will be responsible for freight cost to Whynter's service department), along with an explanation of the claim to Whynter LLC. A return authorization number issued by Whynter is required for all warranty claims and returns. Please package the WHYNTER product carefully in its original packaging material to avoid damage in transit. The original box and packaging material should be retained, as Whynter is not responsible for the cost of replacement packaging. Under this warranty, Whynter will repair or replace any parts found defective at our discretion. This warranty is not transferable. After the expiration of the warranty, the cost of labor and parts will be the responsibility of the original owner of the unit.

## **THIS WARRANTY DOES NOT COVER:**

- Acts of God, such as fire, flood, hurricanes, earthquakes and tornadoes.
- Improper power supply such as power surge, low voltage, defective household wiring or inadequate fuses.
- Use in commercial or industrial applications.
- Damage, accidental or otherwise, to the product while in the possession of a consumer not caused by a defect in material or workmanship.
- Damage caused by consumer misuse, tampering, lack of maintenance or failure to follow the care and special handling provisions in the instructions.
- Damage to the finish of the case, or other appearance parts caused by wear.
- Damage caused by repairs or alterations to the product by anyone other than authorized by the manufacturer.
- Removal, Replacement Packaging, Freight and Insurance cost for the warranty service.
- Products sold AS IS or from an unauthorized reseller.
- Products that have had their serial numbers removed or defaced.

## **DISCLAIMER OF IMPLIED WARRANTIES; LIMITATION OF REMEDIES**

*CUSTOMER'S SOLE AND EXCLUSIVE REMEDY UNDER THIS LIMITED WARRANTY SHALL BE PRODUCT REPAIR OR REPLACEMENT AS PROVIDED HEREIN. CLAIMS BASED ON IMPLIED WARRANTIES, INCLUDING WARRANTIES OF MERCHANTABILITY OR FITNESS FOR A PARTICULAR PURPOSE, ARE LIMITED TO ONE YEAR OR THE SHORTEST PERIOD ALLOWED BY LAW, BUT NOT LESS THAN ONE YEAR. WHYNTER SHALL NOT BE LIABLE FOR CONSEQUENTIAL OR INCIDENTAL DAMAGES SUCH AS PROPERTY DAMAGE AND INCIDENTAL EXPENSES RESULTING FROM ANY BREACH OF THIS WRITTEN LIMITED WARRANTY OR ANY IMPLIED WARRANTY. SOME STATES AND PROVINCES DO NOT ALLOW THE EXCLUSION OR LIMITATION OF INCIDENTAL OR CONSEQUENTIAL DAMAGES, OR LIMITATIONS ON THE DURATION OF IMPLIED WARRANTIES, SO THESE LIMITATIONS OR EXCLUSIONS MAY NOT APPLY TO YOU. THIS WRITTEN WARRANTY GIVES YOU SPECIFIC LEGAL RIGHTS. YOU MAY ALSO HAVE OTHER RIGHTS THAT VARY FROM STATE TO STATE.*

**Please retain the original proof of purchase in order to obtain warranty services.**

**Warranty begins from the original date of purchase.**

To obtain service or information, contact

Whynter LLC via email at [support@whynter.com](mailto:support@whynter.com) or call

866-WHYNTER.

Product contents and specifications may change without notice.

Copyright © 2023 Whynter LLC

WWW.WHYNTER.COM