

## Whynter Mini Split Inverter Ductless Air Conditioner System Air Conditioner & Heat Pump

### OPERATION MANUAL



For models:

**MSFS-009H11517-01NE**

**MSFS-012H11517-01NE**

**MSFS-012H23017-01NE**

**MSFS-012H11522-01ES**



Congratulations on your new Whynter product. To ensure proper operation, please read this Instruction Manual carefully before using this product. Keep this manual in a safe place for future reference.

# TABLE OF CONTENTS

	<b>PAGE</b>
DISPOSAL INFORMATION	<b>3</b>
SAFETY PRECAUTIONS	<b>4</b>
INTRODUCTION	<b>5</b>
TECHNICAL DATA	<b>7</b>
PARTS IDENTIFICATION	<b>8</b>
OPERATING TEMPERATURE / USING THE REMOTE CONTROL	<b>9</b>
FEATURES OF THE REMOTE CONTROL / DISPLAY	<b>10 - 11</b>
MODES OF OPERATION INSTRUCTIONS	<b>12 - 13</b>
SPECIAL FUNCTION FEATURES / DISPLAY PANEL	<b>14 - 15</b>
CARE AND MAINTENANCE	<b>16 - 17</b>
OPERATION TIPS	<b>18 - 19</b>
TROUBLESHOOTING	<b>20 - 21</b>
WARRANTY INFORMATION	<b>22</b>

## DISPOSAL INFORMATION

Thank you for choosing the Whynter Mini Split Inverter Ductless Air Conditioner System Air Conditioner & Heat Pump. Please follow the instructions provided in this user guide to obtain the very best performance from your split air conditioner and take full advantage of the many features your air conditioner offers you. We trust that your Whynter air conditioner will provide the performance and reliability that we stand for.

Please keep this user manual in a safe place for future reference.

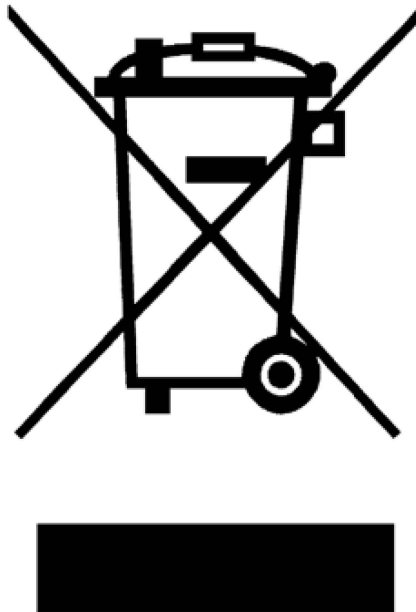

This symbol on the product or its packaging indicates that the appliance cannot be treated as normal domestic trash, but must be handed in at a collection point for recycling electric and electronic appliances. Your contribution to the correct disposal of this product protects the environment. Further information about the recycling of this product can be obtained from your local municipal authority.

## SAFETY PRECAUTIONS

### **WARNING**

TO REDUCE THE RISK OF FIRE, ELECTRICAL SHOCK, OR INJURY WHEN USING YOUR AIR CONDITIONER, FOLLOW THESE BASIC PRECAUTIONS:

Before the appliance is used, it must be properly positioned and installed as detailed in this manual.

- Please read this manual entirely before installing and using this appliance and follow all instructions and general safety rules carefully. High voltages and pressures existing within this unit can cause serious harm to persons or property or even death. Installation must be performed in accordance with the requirement of NEC and CEC by authorized certified HVAC contractor only. Improper installation will cause irreversible damages and serious safety risks.
- Installation must be performed according to all applicable and current national and local codes, regulations and laws.
- During the installation, the area within the indoor and outdoor sections of this split system must be restricted to all unauthorized personnel to avoid any accidents.
- Both indoor and the outdoor units must be firmly fixed to the proper parts of the building's structure.
- Sensitive components in this unit are protected by a fuse installed on the electronic card located in the indoor unit. Rating of this fuse is 5 Amps / 250 V. Only replace the fuse with the same rating when needed.
- System power should be attached to the outdoor unit through a properly rated independent power circuit protected by a properly rated circuit breaker and a service disconnect switch box located near the outdoor unit.
- Ensure that the incoming voltage corresponds with the required power written on the rating plate. Make all connections tightly and waterproof to avoid risk of electrical shocks or fire due to insufficient contact.
- All power wires, breakers and other components used to supply power to the unit must be approved for such use and properly rated for the load.
- Always disconnect power before servicing.
- This unit contains no user-serviceable parts. Always consult authorized service personnel for installation, repairing, and relocation of this product. Improper installation or handling will cause leakage, electrical shock, or fire.
- If any parts such as the power cord is damaged, replacement or repair work shall be performed by authorized personnel only.
- This appliance is not intended for use by persons (including children) with reduced physical, sensory or mental capabilities, or lack of experience and knowledge, unless they have been given supervision or instruction concerning use of the appliance by persons responsible for their safety.
- Children should be supervised to ensure that they do not play with the appliance.
- In the event of a malfunction such as burning smell, immediately stop operation of the air conditioner, and disconnect all the power supply by turning off the electrical breaker or disconnecting the power plug. Then consult authorized HVAC service personnel.
- In the event of refrigerant leakage, be sure to keep away from fire or any flammables, and consult authorized HVAC service personnel.
- Ensure that any electronic equipment is at least 1 meter / 3 feet away from either the indoor unit or outdoor unit.
- Do not climb on, place objects on, or hang objects from the unit.
- Do not expose the unit directly to water.
- Do not insert your fingers or any other objects into outlet port, open panel, or intake grille.

**THE MANUFACTURER DISCLAIMS ANY RESPONSIBILITY IF THE ABOVE INSTRUCTIONS ARE NOT FOLLOWED.**

## SAFETY PRECAUTIONS

### CAUTION

TO REDUCE THE RISK OF FIRE, ELECTRICAL SHOCK, OR INJURY WHEN USING YOUR AIR CONDITIONER, FOLLOW THESE BASIC PRECAUTIONS:

- Air always contains some level of humidity. Any air left within the system or entering into the system will cause insufficient performance and irreversible internal compressor damage.
- Installer must carry out cycle tests and monitor and record of all related operational data before leaving the scene.
- Do not locate the system components near any inflammable substances, pressurized containers and moisture containing items.
- All packing materials are recyclable, please discard properly.
- Operate and regularly maintain the system as instructed in this manual.
- Warranty is valid only when the equipment is installed properly by licensed HVAC contractors and the warranty registration card must be properly filled out and sent to the manufacturer.
- System components must be installed where they can be accessed for maintenance and repairs easily. Sufficient clearances must be provided at all directions for removal of various panels.
- If you see lightning or hear thunder, there might be a lightning strike. To prevent electric shock hazard, turn off the air conditioner by using the remote control, and do not touch the unit or the power plug during thunder-storm.
- Always operate the unit with air filters installed.
- Always turn off the appliance when cleaning the air filter, and transporting.
- Unplug the power supply cable when not using the indoor unit for an extended period.
- Do not block or cover the intake grille and the outlet port.
- Do not place any other electrical products or household items under indoor unit or outdoor unit as dripping condensation from the unit might get them wet, and may cause damage or malfunction of your property.
- Do not abuse, sit on, or stand on the appliance.
- Do not drink or let pet(s) drink the drainage from the air conditioner.
- Do not touch the aluminum fins of heat exchanger built-in the indoor or outdoor unit to avoid personal injury when you install or maintain the unit.
- Do not operate with wet hands.
- The design and specifications are subject to change without prior notice for product improvement.

### IMPORTANT

**This Whynter Mini Split Inverter Ductless Air Conditioner system is designed to be a one-to-one unit system, consisting of 1 indoor unit matched with 1 outdoor unit. Multiple indoor unit(s) cannot be combined with the outdoor unit. If indoor or outdoor units are purchased individually, ensure that indoor and outdoor unit are compatible with each other before purchasing to avoid performance and operation issues.**

*THE MANUFACTURER DISCLAIMS ANY RESPONSIBILITY IF THE ABOVE INSTRUCTIONS ARE NOT FOLLOWED.*

# INTRODUCTION

## HOW IT WORKS

Ductless Mini Split system is the newest thing to hit the HVAC industry. This is a new and energy efficient way to cool and heat a living or working space. The technology goes by many names – ductless air conditioning, mini split air conditioner, mini ductless ac and others.

Ductless Mini Split systems use 2 units, One Inside (Indoor unit; the evaporator) and One Outside (Outdoor unit; the condenser). Essentially, this is an air conditioner that is split into 2 units, similar to central air conditioning. The difference is that split air conditioning consists of 2 units that are placed relatively close to each other. Best of all, you do not need to perform any additional ductwork in your home, because this technology uses no ducts at all.

The outside unit is the compressor unit, just like you'd see in a central air conditioner system. The inside unit simply hangs on the wall, and hoses and wires connect the 2 units together.

There are many advantages to Ductless Mini Split systems:

1. The installation is simple and quick.
2. The system is energy efficient because:
  - Cooled air is not blown through duct work. Energy wasted in long lengths of uninhabited ductwork means higher energy bills.
  - With Central Air you must cool an entire home when only one room may need cooling. On the other hand, ductless mini-splits cool only the areas you want and not the areas you don't.
3. The air conditioner is also a mini split heat pump, so you get year-round use of the unit.
4. Ultra quiet operation as the louder components like compressors and motors are installed outdoors.

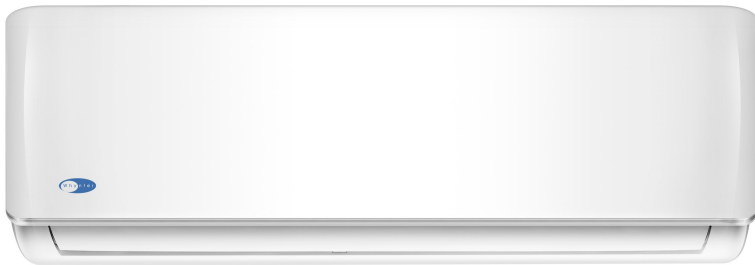

The advanced inverter technology used in the Whynter Mini Split Inverter Ductless Air Conditioners is the latest evolution of technology concerning the electro motors of the compressors. An inverter is used to control the speed of the compressor motor, so as to continuously regulate the temperature.

When the inverter air conditioning is switched on, the compressor operates at a high speed in order to cool or heat the room quickly. As the room temperature approaches the set temperature, the compressor slows down, maintaining a constant temperature and saving energy. Any sudden fluctuation in the room temperature will be sensed and instantly adjusted to bring the room temperature back to the set temperature. Below are the advantages of inverter technology.

- At least 30% - 50% less expensive to run as it consumes less power
- Quicker to achieve desired temperature
- Quieter operation
- No temperature fluctuations
- No voltage peaks from compressor

## TECHNICAL DATA

<b>Full Set Model#:</b>	MSFS-009H11517-01NE	MSFS-012H11517-01NE	MSFS-012H11522-01ES	MSFS-012H23017-01NE
<b>Indoor Unit Model#:</b>	MSI-009H11517-01NE	MSI-012H11517-01NE	MSI-012H11522-01ES	MSI-012H23017-01NE
<b>Outdoor Unit Model#:</b>	MSO-009H11517-01NE	MSO-012H11517-01NE	MSO-012H11522-01ES	MSO-012H23017-01NE
<b>Operational Modes:</b>	Auto, Cool, Fan, Dry, and Heat	Auto, Cool, Fan, Dry, and Heat	Auto, Cool, Fan, Dry, and Heat	Auto, Cool, Fan, Dry, and Heat
<b>Cooling Capacity:</b>	9000 BTU	12000 BTU	12000 BTU	12000 BTU
<b>Heating Capacity:</b>	9500 BTU	12000 BTU	12000 BTU	11800 BTU
<b>Coverage Area:</b>	250 - 350 sq. ft	350 - 450 sq. ft.	350 - 450 sq. ft.	350 - 450 sq. ft.
<b>Dehumidifying Capacity:</b>	21.6 L	28.8 L	28.8 L	28.8 L
<b>Fan Speed:</b>	3 Fan Speed	3 Fan Speed	3 Fan Speed	3 Fan Speed
<b>Filters:</b>	3M + carbon Filter (2) High Density Filter (2)	3M + carbon Filter (2) High Density Filter (2)	3M + carbon Filter (2) High Density Filter (2)	3M + carbon Filter (2) High Density Filter (2)
<b>Thermostat Control Range (cooling/heating):</b>	62° - 86°F	62° - 86°F	62° - 86°F	62° - 86°F
<b>Recommended operating temperature (cooling/heating):</b>	62° - 90°F / 32° - 86°F	62° - 90°F / 32° - 86°F	62° - 90°F / 32° - 86°F	62° - 90°F / 32° - 86°F
<b>Timer:</b>	24 hour programmable timer	24 hour programmable timer	24 hour programmable timer	24 hour programmable timer
<b>Noise Level:</b>	< 40 - 24 dBA	< 40 - 24 dBA	< 44 - 29 dBA	< 40 - 24 dBA
<b>Refrigerant:</b>	R410A	R410A	R410A	R410A
<b>Air Flow (at high speed):</b>	247 CFM	294 CFM	370 CFM	294 CFM
<b>Maximum Power Consumption:</b>	782W / 7.0Amps	1200W / 10.4Amps	960W / 8.4Amps	1090W / 4.8Amps
<b>Power Supply:</b>	115 V / 60Hz	115 V / 60Hz	115 V / 60Hz	230 V / 60Hz
<b>EER:</b>	11.5	10.5	12.5	11
<b>SEER:</b>	17 SEER	17 SEER	22 SEER Energy Star	17 SEER
<b>Unit Dimensions:</b>	29" W x 8" D x 12" H (Indoor Unit) 31" W x 12" D x 22" H (Outdoor Unit)	32" W x 8" D x 12" H (Indoor Unit) 31" W x 12" D x 22" H (Outdoor Unit)	32" W x 8" D x 12" H (Indoor Unit) 32" W x 14" x 22" H (Outdoor Unit)	32" W x 8" D x 12" H (Indoor Unit) 31" W x 12" D x 22" H (Outdoor Unit)
<b>Package Dimensions:</b>	32" W x 11" D x 15" H (Indoor Unit) 36" W x 14" D x 24" H (Outdoor Unit)	35" W x 12" D x 15" H (Indoor Unit) 36" W x 14" D x 24" H (Outdoor Unit)	35" W x 12" D x 15" H (Indoor Unit) 37" W x 16" D x 25" (Outdoor Unit)	35" W x 12" D x 15" H (Indoor Unit) 36" W x 14" D x 24" H (Outdoor Unit)
<b>Net Weight:</b>	17 lbs (Indoor Unit) 64 lbs (Outdoor Unit)	19 lbs (Indoor Unit) 66 lbs (Outdoor Unit)	19 lbs (Indoor Unit) 82 lbs (Outdoor Unit)	19 lbs (Indoor Unit) 66 lbs (Outdoor Unit)
<b>Gross Weight:</b>	21 lbs (Indoor Unit) 70 lbs (Outdoor Unit)	23 lbs (Indoor Unit) 71 lbs (Outdoor Unit)	23 lbs (Indoor Unit) 88 lbs (Outdoor Unit)	23 lbs (Indoor Unit) 71 lbs (Outdoor Unit)
<b>UPC (Full Set)</b>	852749006405	852749006436	852749006498	852749006467
<b>UPC (Indoor Unit)</b>	852749006412	852749006443	852749006504	852749006474
<b>UPC (Outdoor Unit)</b>	852749006429	852749006450	852749006511	852749006481

# PARTS IDENTIFICATION

## Indoor Unit

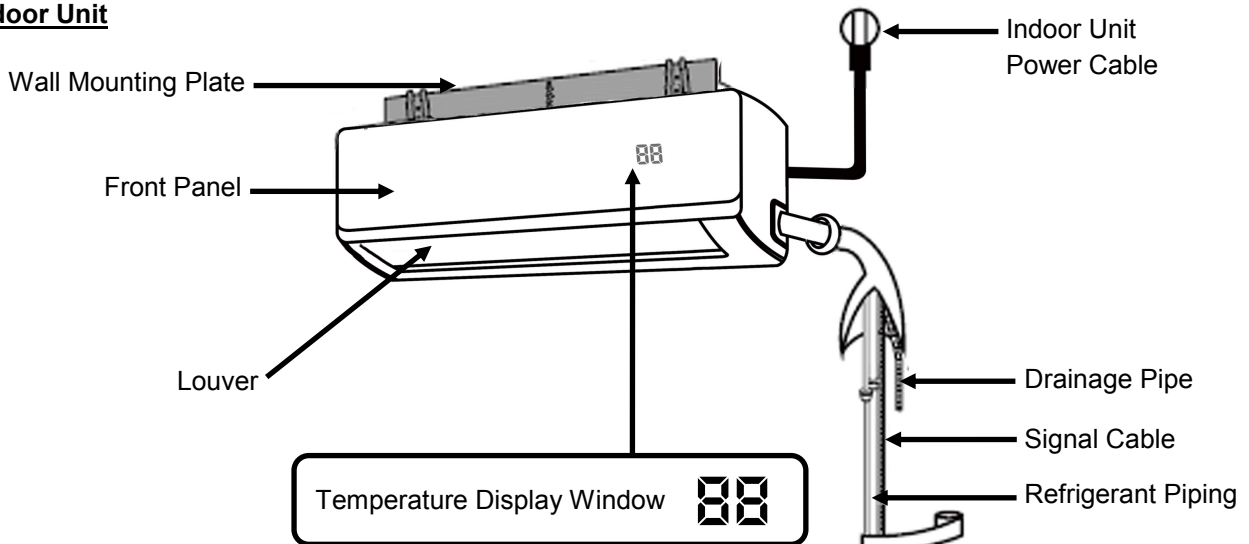

## Outdoor Unit

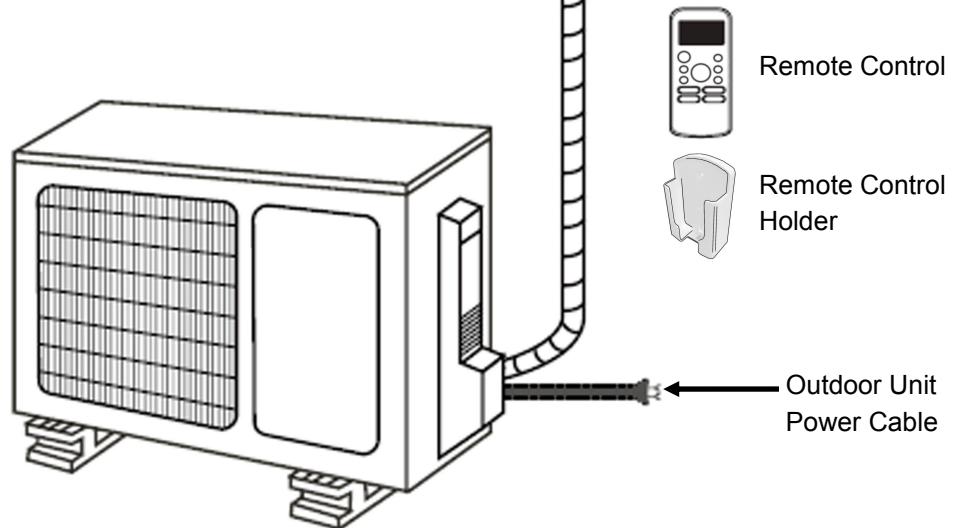

## Front Panel Open View

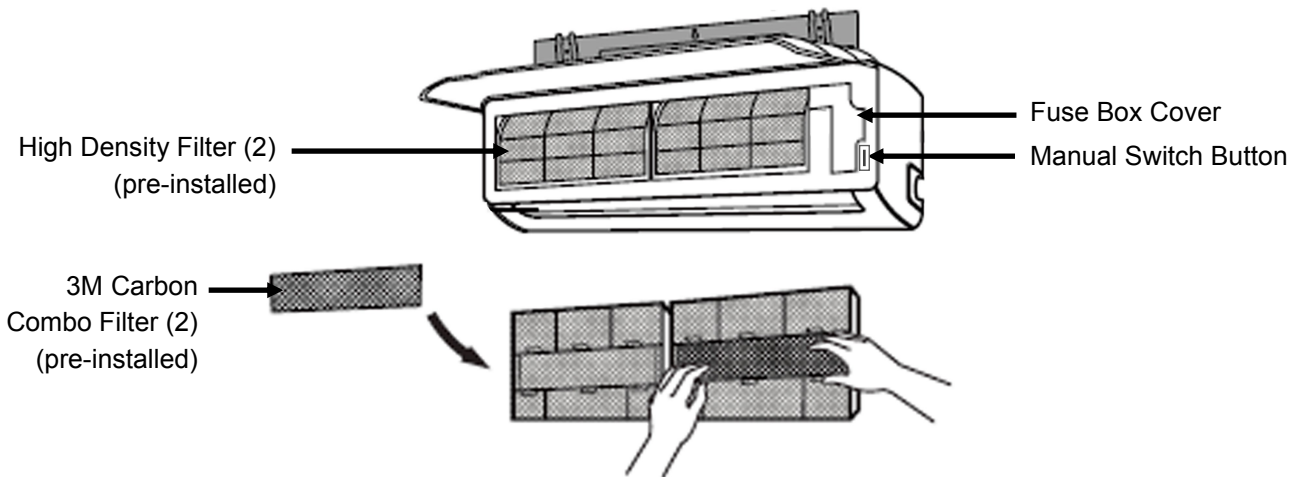

**NOTE:** Illustrations in this manual are for explanatory purposes. The actual shape of your indoor unit may be slightly different. The actual shape shall prevail.



## OPERATING TEMPERATURE

	Cool Mode	Heat Mode	Dry Mode
Room Temperature	62°F - 90°F / 17°C - 32°C	32°F - 86°F / 0°C - 30°C	50°F - 90°F / 10°C - 32°C
Outdoor Temperature	32°F - 122°F / 0°C - 50°C	5°F - 86°F / -15°C - 30°C	32°F - 122°F / 0°C - 50°C

### NOTE:

1. Optimum performance will be achieved within these operating temperatures. If air conditioner is used outside of the above conditions, certain safety protection features might come into operation and cause the unit to function abnormally.
2. If the air conditioner runs for a long time in cooling mode and the humidity is high (over 80%), condensed water may drip out of the unit. Please set the vertical air flow louver to its maximum angle (vertically to the floor), and set the unit to HIGH fan mode.

## USING THE REMOTE CONTROL

### Location of the Remote Control

- Keep the remote control where its signals can reach the receiver of the indoor unit (a distance of 26 feet is allowed).
- If you keep the remote control in a position that hinders proper signal transmission, a time lag of up to 15 minutes may occur.

### CAUTION:

To prevent malfunction or damage of the remote control:

- Do not place the remote control at where will not be exposed to direct sunlight or excessive heat.
- Remove batteries if the product is not going to be used for an extended period.
- Do not drop or apply strong pressure to the remote control.
- Do not expose the remote control to liquids.
- If leaking battery fluid comes in contact with your skin, eyes, or mouth, immediately rinse with plenty of clean water, and consult your physician.
- Use of other electrical appliances or nearby use of a wireless radio transmitter may cause the malfunction of the remote control.

### Replacing batteries

The remote control uses two AAA dry batteries (included)

1. Slide the cover of the battery compartment off according to the arrow direction, then replace the old batteries with new ones.
  2. Insert the new batteries making sure that the(+) and (-) of battery are installed correctly.
  3. Reattach the cover by sliding it back into position. After replacing the batteries, set the remote control clock.
- NOTE: Do not dispose batteries as unsorted municipal waste. Collection of such waste separately for special treatment is necessary.

## FEATURES OF THE REMOTE CONTROL

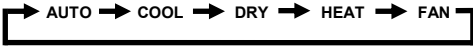
1. ON/OFF Button	Press this button to start or stop operation.
2. MODE Button	<p>Press this button to select function mode in the follow order: AUTO, COOL, DRY, HEAT, and FAN</p> 
3. FAN Button	Press this button to change Fan Speed in 4 speeds - AUTO LOW MED or HIGH. The fan speed can not be selected in AUTO and DRY mode .
4. SLEEP Button	<p>Press this button to select the Sleep mode. This function can only be used in AUTO, COOL and HEAT modes. Press Sleep button again to cancel.</p> <p><b>NOTE:</b> Changing function mode or fan speed will cancel the Sleep mode.</p>
5. TURBO Button	Press this button in FAN, COOL or HEAT mode, the fan speed will be set at maximum speed. Push again to cancel the TURBO function.
SELF CLEAN Button	Press this button to activate Self Clean function.
6. LED Button	Press this button to activate indoor unit light display. Press LED button again to turn off indoor unit light display.
FOLLOW ME Button	<p>Press this button to initiate the Follow Me feature and the remote control will display the temperature at its location. The remote control will send this signal to the air conditioner every 3 minutes interval until you press the Follow Me button again. The air conditioner will automatically cancel the Follow Me feature if it does not receive the signal during any 7 minutes interval.</p> <p><b>NOTE:</b> The Follow Me feature is not available in DRY and FAN mode. Shifting the operating mode or turning off the unit will cancel the Follow Me feature automatically. The remote control needs to be within 26 feet reach of the indoor unit for the Follow Me mode to work appropriately.</p>

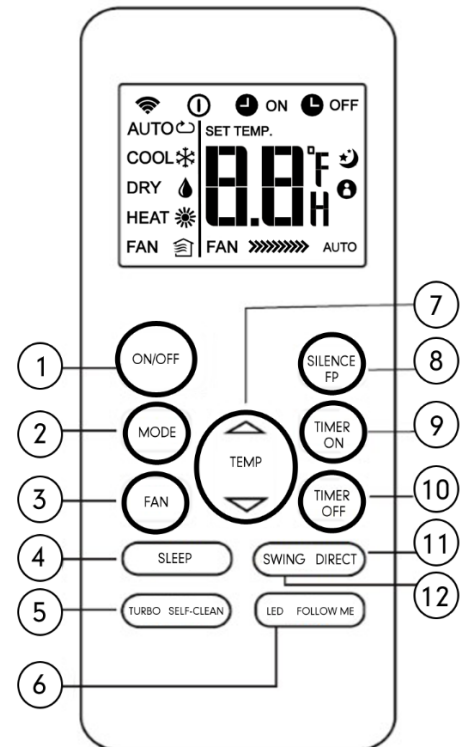

**Note:**

Only use the remote control provided with the unit.

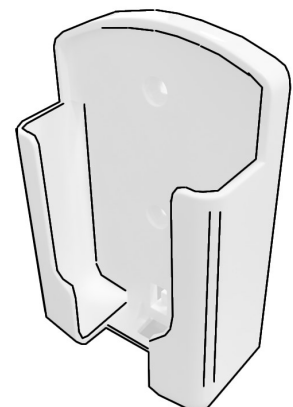













**Remote Control Holder**

Install the remote control holder in a place where the signal can be received by the indoor unit

## FEATURES OF THE REMOTE CONTROL / DISPLAY

<b>7. UP and DOWN Button</b>	<p>Press the UP button to increase the indoor temperature setting or to adjust the TIMER (clock time) in a clockwise direction. Press the DOWN button to decrease the indoor temperature setting or to adjust the TIMER (clock time) in a counter-clockwise direction.</p> <p><b>NOTE:</b> Pressing and holding the UP and DOWN buttons together for 3 seconds will alternate the temperature display between the C &amp; F scale.</p>
<b>8. SILENCE / FP Button</b>	<p>Press Silence button once activate Silence mode. When activated, the compressor will operate at low frequency and the indoor unit will bring faint breeze, which will reduce the noise to the lowest level and create a quiet and comfortable room for you. Due to low frequency operation of compressor, it may result in insufficient cooling and heating capacity.</p> <p>Press FP button for 2 seconds to active FP function (Freezing Protection). The unit will operate at a set temperature of 46°F. The display window of the indoor unit will display FP. Press the buttons of ON/OFF, SLEEP, FP, MODE, FAN SPEED UP or DOWN while operating will cancel the FP function.</p> <p>Note: FP can only be activated only on HEAT mode.</p>
<b>9. TIMER ON Button</b>	<p>Press the Timer On button to program Timer Delayed Switch ON function</p>
<b>10. TIMER OFF Button</b>	<p>Press the Timer Off button to program Timer Delayed Switch OFF function</p>
<b>11. DIRECT Button</b>	<p>Press to change the louver movement and set the desired up/down air flow direction. The louver changes 6° in angle for each press.</p>
<b>12. SWING Button</b>	<p>Press to stop or start horizontal louver auto-swing feature.</p>

<b>Mode Display</b> Displays the current operation mode. Including Auto, Cool, Dry, Heat, and Fan.	 <b>Sleep Display</b> Displays when SLEEP mode is set. Press the SLEEP button again to turn off. 
<b>Transmission Indicator</b> This transmission indicator lights when remote control transmits signals to the indoor unit.	 <b>FOLLOW ME Display</b> Displays when FOLLOW ME function is activated. 
<b>ON/OFF display</b> Displays when the unit is On. Press the ON/OFF button again to turn off the unit.	 <b>Temperature/Timer display</b> Displays the timer set in (H) hourly increments and temperature settings in (°F) degree increments. When unit is in FAN mode, no temperature setting is displayed. 
<b>TIMER ON display</b> Displays when TIMER ON time is set  ON  OFF	<b>Fan Speed Display</b> Displays the selected fan speed: AUTO (no display), LOW  , MED  , and HIGH  . The fan speed is automatically set to AUTO when the operating mode on either AUTO or DRY mode. 

**NOTE:** This air conditioner is equipped with an emergency switch which can be accessed by opening the front panel. This switch is used for manual operation in case the remote control fails to operate. See page 15

## MODES OF OPERATION

### AUTO MODE OPERATION

When you set the air conditioner in AUTO mode, it will automatically select cooling, heating, or fan only operation depending on what temperature you have selected and the room temperature. The indoor unit has a preset temperature of 76°F when AUTO mode is initially started.

- If the room temperature is 1°F(2°C) higher than the set temperature, the air conditioner will run in Cool mode.
- If the room temperature is 1°F(2°C) lower than the set temperature, the air conditioner will run in Heat mode.
- If the room temperature is 1°F(2°C) within the set temperature, the air conditioner will run in Fan mode.

**NOTE:** The fan speed is automatically selected and cannot be changed

### COOL MODE OPERATION

In this mode, the air conditioner cools and dehumidifies the room. To activate this function mode, press the MODE button on the remote control until the COOL indicator display comes on. When the cooling mode is set, the compressor will start in approximately 3 minutes.

The cooling temperature setting range of this air conditioner is from 62°F-86°F. To set the temperature, press the UP and DOWN buttons. This air conditioner has a 5°F temperature cushion which if the set temperature is within 5°F of the ambient temperature, the unit runs on fan only mode. This saves energy and prolongs the life of the compressor of the air conditioner.

To set the fan speed, press the FAN button. In cooling mode, the difference in noise level between the 3 fan speeds is not very noticeable. Try setting the unit to Fan only mode, you should be able to hear the difference between high and low fan speed settings.

### DRY MODE OPERATION

In this mode, the air conditioner only dehumidifies the room, the compressor will activate intermittently depending on the ambient temperature and the fan speed is set to LOW. To activate this function mode, press the MODE button on the remote control until the DRY indicator display comes on. Please note that when switching function mode, there will be an approximately 3 minute transition time.

NOTE: Fan speed is defaulted to AUTO and cannot be changed in Dry Mode.

### FAN MODE OPERATION

In this mode, the outdoor unit is deactivated and only the indoor unit's fan runs without any cooling or heating effect. To activate this function mode, press the MODE button on the remote control until the FAN indicator display comes on. Temperature setting buttons are deactivated. However, fan speed can still be adjusted as desired.

### HEAT MODE OPERATION

This air conditioner operates on the heat-pump principle, absorbing heat from air outdoors and transferring that heat to the indoor unit. In this mode, the air conditioner heats the room. To activate this function mode, press the MODE button on the remote control until the HEAT indicator display comes on. When the heating mode is set, the compressor will start in approximately 3-5 minutes.

The heating temperature setting range of this air conditioner is from 62°F-86°F. To set the temperature, press the UP and DOWN buttons.

To set the fan speed, press the FAN button. In heating mode, the difference in noise level between the 3 fan speeds is not very noticeable. Try setting the unit to Fan only mode, you should be able to hear the difference between high and low fan speed settings.

### TIMER ON SETTING

With the air conditioner is off, press the TIMER button. The TIMER ON light will come on. Then set the desired time delay ON hours by pressing the UP and DOWN buttons. The time increments are at 0.5 hour to up to 10 hours, followed by 1 hour increment up to 24 hours. When the delay time set has elapsed, the air conditioner switches on. To cancel the delayed switch on function, turn on the air conditioner or adjust the time setting to 0.0.

### TIMER OFF SETTING

With the air conditioner operating in any function mode, press the TIMER button. The TIMER OFF light will come on. Then set the desired time delay OFF hours by pressing the UP and DOWN buttons. The time increments are at 0.5 hour to up to 10 hours, followed by 1 hour increment up to 24 hours.

## MODES OF OPERATION

When the delay time set has elapsed, the air conditioner switches off. To cancel the delayed switch off function, turn off the air conditioner or adjust the time setting to 0.0.

**NOTE:** *Timer ON and Timer OFF setting can be set at the same time.*

### SLEEP MODE FUNCTION

The SLEEP function is used to decrease energy use while you sleep. In this mode, the air conditioner gradually increases the set temperature in cooling mode and decreases the set temperature in heating mode. In Sleep mode, the set temperature is increased (cooling) or decreased (heating) by 1°C/ 2°F in the first 2 hours. This new temperature will remain the same for 5 hours, after which the air conditioner will automatically switch OFF. To activate this function mode, press the SLEEP button on the remote control until the SLEEP indicator light comes on. This function can only be used in AUTO, COOL and HEAT modes.

**NOTE:** *Changing function mode or fan speed will cancel the Sleep mode*

### AIR FLOW DIRECTION CONTROL

Air flow direction can be remotely controlled by pressing the SWING and DIRECT buttons on the remote control.

- Press the SWING button to activate auto-Swing mode. The horizontal air louvers will start moving up and down. Pressing the SWING button again to cancel the auto-Swing mode and the air louver will stop. Press the DIRECT button to change the louver movement and set the desired up/down air flow direction. The louver changes 6° in angle for each press.

#### NOTES:

- A fixed louver angle in a high / horizontal angle is recommended for COOL and FAN modes for reaching across the room.
- A fixed louver angle in a low / downward angle is recommended for HEAT and DRY modes to prevent creating air draft effect on people.
- Never adjust the louvers by hand to prevent damage to the delicate driver motors.
- Manually adjust the deflector rods to direct the air to the right or left direction as desired. (see Fig. 1)

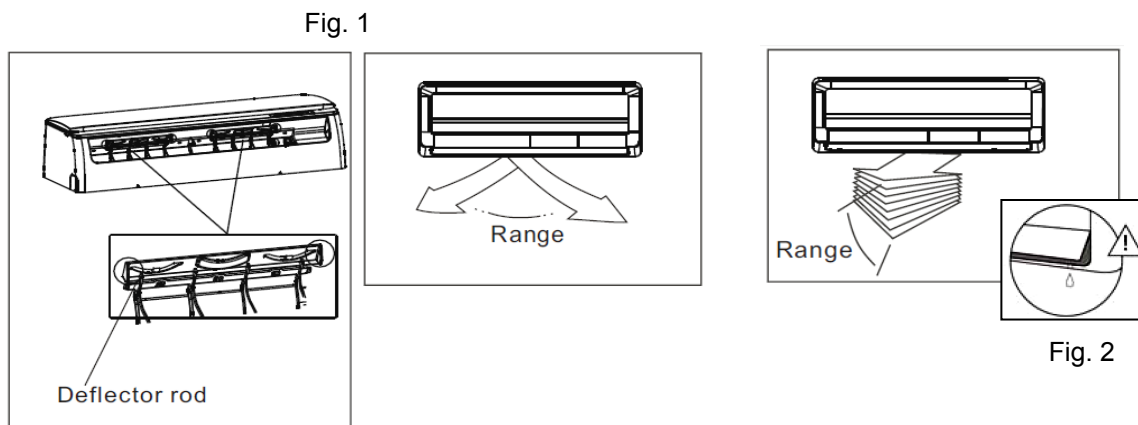

#### ⚠ CAUTION:

- Do not operate the air conditioner for long periods with the air flow direction set downward in cooling or dehumidifying mode. Otherwise, condensation may occur on the surface of the horizontal louver causing moisture to drop on to the floor or on furnishings. (see Fig. 2)
- When the air conditioner is started immediately after it was stopped, the horizontal louver might not move for approximately 10 seconds.
- Open angle of the horizontal louver should not be set too small, as COOLING or HEATING performance may be impaired due to too restricted air flow area.
- Do not move the horizontal louver manually, otherwise the horizontal louver will be out of sync. Turn off the air conditioner for at least 3 minutes, then restart the unit.
- Do not operate unit with horizontal louver in closed position.
- Do not put your fingers in or near the blower and suction side of the unit. The high-speed fan inside the unit may cause injury.

## SPECIAL FUNCTION FEATURES

### TURBO FUNCTION

Turbo function will be helpful to cool or heat your room quickly and effectively by operating at the maximum fan speed.

**NOTE:** Turbo function is only available in Cool and Heat mode.

### LOUVER ANGLE MEMORY FUNCTION

Power failure during operation or pressing the ON/OFF button on the remote control will stop the unit completely. When the power restores or pressing the ON/OFF button on the remote control again, the unit restarts automatically with the previous open angle of the horizontal louver by the louver angle memory function. Press the AUTO/COOL manual button (on the indoor unit) and the open angle of the horizontal louver will be restored to the standard angle.

**NOTE:** It is highly recommend that the open angle of the horizontal louver should not be set too small, in case the condensed water forms and drops from the horizontal louver.

### FOLLOW ME FUNCTION

The remote control serves as a remote thermostat allowing for the precise and comfortable temperature control. With this technology, an efficient temperature sensor is integrated in the remote control. To activate the Follow me function, press Follow Me button on the remote control. Once this function is activated, the remote control will send the temperature signal to the air conditioner every 3 minutes interval until you press the Follow Me button again. The air conditioner will automatically cancel the Follow Me feature if it does not receive the signal during any 7 minutes interval.

**NOTE:** The Follow Me feature is not available in DRY and FAN mode. Shifting the operating mode or turning off the unit will cancel the Follow Me feature automatically. The remote control needs to be within 26 feet reach of the indoor unit for the Follow Me mode to work appropriately.

### SELF-CLEAN FUNCTION

Self Clean function will prevent growth of harmful micro-organisms by eliminating the moisture inside of the indoor unit. In this function, the indoor unit will run in fan mode for 11 minutes. Once the time has elapsed, a low heat operation will run for 1 minute and will then switch to fan mode for another 2 minutes. The appliance will automatically shut-off once the cycle completes.

**NOTE:** It is recommended the use the Self Clean function every 15 days. In high humidity environment, use it in a weekly basis. This will prevent rusting of the air conditioner's evaporator coil.

### SILENCE FUNCTION

Press the "Silence" button on the remote control to initiate Silence function. When the Silence function is activated, the compressor will run at a low frequency rate and the indoor unit will bring faint breeze, which will reduce the noise to the lowest level and create a quiet and comfortable environment.

### LOW TEMPERATURE HEATING (FP mode)

The FP (Freezing Protection) mode is designed to run at ambient temperature as low as 46°F / 8°C, which keeps the room temperature at a comfortable level during the winter season.

**NOTE:** This unit uses heat pump for heating and the heating mode does not work when temperature is below 45°F.

### REFRIGERANT LEAKAGE DETECTION

With this safety feature, the indoor unit will display "EC" when it detects a refrigerant leakage.

### ANTI-COLD AIR FUNCTION

The unit is designed not to blow cold air on HEAT mode when the indoor heat exchanger is in one of the following three situations and the set temperature has not been reached.

- A) When heating has just started
- B) Defrosting
- C) Low temperature heating

To prevent cold air flow, the indoor unit's fan will stop if the indoor coil temperature is lower than 62°F(17°C). The fan operation will resume once the indoor coil's temperature is higher than 88°F.



## DISPLAY PANEL / SPECIAL FUNCTION FEATURES

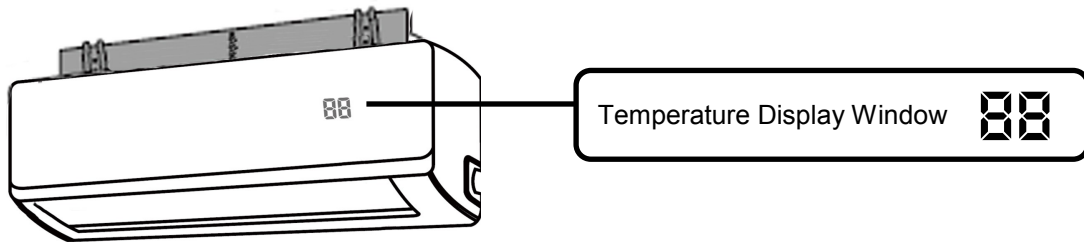

### Temperature and Function Display

- In FAN mode: shows room temperature.
- In other modes, the unit will display your temperature setting in °C or °F and AUTO timer setting.
- Display functions of the air conditioner:
  - \* Displays “ON” for three seconds when Timer ON, Swing, Turbo or Sleep feature is activated.
  - \* Displays “OF” for three seconds when Timer OFF is set and when Swing, Turbo or Sleep feature is cancelled.
  - \* Displays “dF” when air conditioner is running in Defrost mode.
  - \* Displays “cF” when anti-cold air feature is activated in Heating mode.
  - \* Displays “SC” when air conditioner is running in Self-clean mode.
  - \* Displays “FP” when air conditioner is running in Low Temperature Heating.
  - \* Displays and spells “ECO” when ECO function is activated.
  - \* Displays “EC” when air conditioner detects refrigerant leakage.
  - \* Displays “CL” as a reminder clean air filters.
  - \* Displays “nF” as a reminder replace air filters.

## MANUAL OPERATION (WITHOUT REMOTE CONTROL)

In the event that your remote control fails to work, your unit can be operated manually with the manual Auto/Cool button located on the indoor unit. Note that manual operation is not a long-term solution, and that operating the unit with your remote control is strongly recommended.

**CAUTION:** *The manual button is intended for testing purposes and emergency operation only. Please do not use this function unless the remote is lost and it is absolutely necessary. To restore regular operation, use the remote control to activate the unit.*

Before manual operation, unit must be turned off. To operate your unit manually:

- 1 . Open the front panel of the indoor unit.
- 2 . Locate the manual Auto/Cool button on the right-hand side of the unit.
- 3 . Press the manual Auto/Cool button one time to activate FORCED AUTO mode.
- 4 . Press the manual Auto/Cool button again to activate FORCED COOLING mode.
- 5 . Press the MANUAL CONTROL button a third time to turn the unit off.
- 6 . Close the front panel.

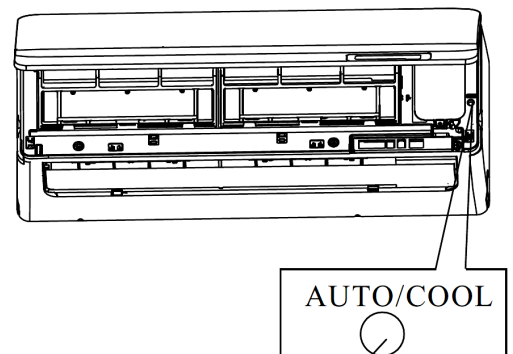

Manual switch

## CARE AND MAINTENANCE

### **WARNING!**

- Never operate the air conditioner without the filters in place.
- Before cleaning the indoor unit, ensure the unit is turned off and all the power supply has been disconnected.
- Do not touch the aluminum fins of heat exchanger built-in the indoor unit to avoid personal injury when you maintain the unit.

### **CAUTION**

Only use a soft, dry cloth to wipe the unit clean. If the unit is especially dirty, you can use a cloth soaked in warm water to wipe it clean.

- Do not use chemicals or chemically treated cloths to clean the unit.
- Do not use benzene, paint thinner, polishing powder or other solvents to clean the unit. They can cause the plastic surface to crack or deform.
- Do not use water hotter than 104°F (40°C) to clean the front panel. This can cause the panel to deform or become discolored.
- Do not expose filter to direct sunlight when drying. This can shrink the filter.

### **CLEANING THE AIR FILTER**

Note: The high density filters and 3M carbon filters come pre-installed.

To ensure the air intake is filtered properly and to assure that your air conditioner runs efficiently, it is recommended to clean the washable high density filters at least once every two weeks.

1. Lift the indoor unit panel up to an angle until it stops with a clicking sound. (See Fig. 15.1)
2. Pull up the handle of the high density filters in direction of the arrow and release from the filter holder. Then pull the filters out with gently sliding it downward. (See Fig. 15.2 and 15.3)

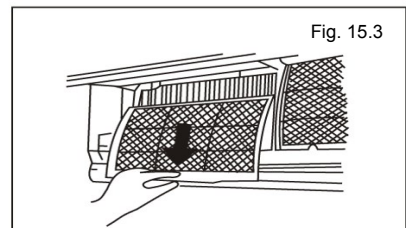
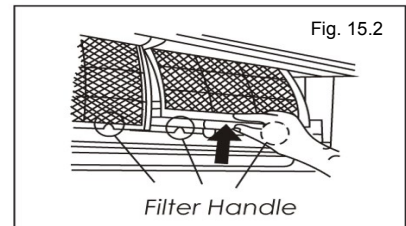
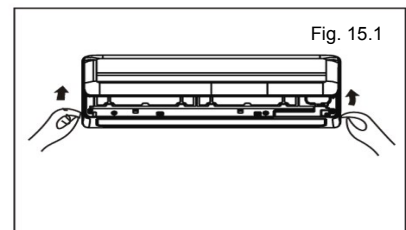
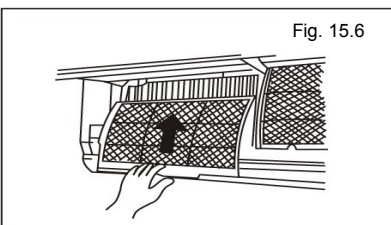
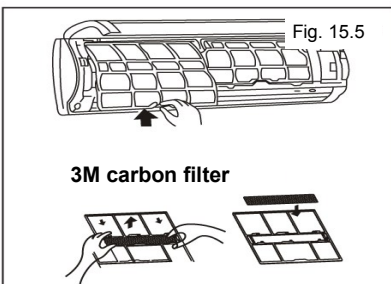
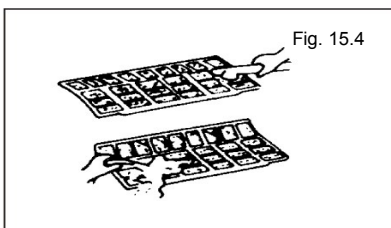

3. Use a vacuum cleaner or tap lightly to remove loose dust and dirt from the high density filters. Then rinse them thoroughly under warm or cold running water (no hotter than 100F). (See Fig. 15.4)

4. Remove the two 3M carbon filters from its supporting frames. Clean the high density filters least once a month and replace it every 4-5 months. Clean it with vacuum cleaner, then dry it in cool place. (See Fig. 15.5)

5. Install the two 3M carbon filters back into position.

6. Insert the upper portion of air filters back into the unit, taking care that the left and right edges line up correctly and place filters into position. (See Fig 15.6). Close the front panel of the indoor unit.



## CARE AND MAINTENANCE

### AIR FILTER CLEANING REMINDER

After 240 hours of use, the display window on the indoor unit will flash "CL." This is a reminder to clean your filter. After 15 seconds, the unit will revert to its previous display. To reset the reminder, press the LED button on your remote control 4 times, or press the MANUAL CONTROL button 3 times. If you do not reset the reminder, the "CL" indicator will flash again when you restart the unit.

### AIR FILTER REPLACEMENT REMINDER

After 2,880 hours of use, the display window on the indoor unit will flash "nF." This is a reminder to replace your 3M carbon filters. After 15 seconds, the unit will revert to its previous display. To reset the reminder, press the LED button on your remote control 4 times, or press the MANUAL CONTROL button 3 times. If you don't reset the reminder, the "nF" indicator will flash again when you restart the unit.

### CAUTION

- Any maintenance and cleaning of outdoor unit should be performed by an authorized dealer or licensed service provider.
- Any unit repairs should be performed by authorized dealer or licensed service provider.

### MAINTENANCE - LONG PERIODS OF NON-USE



If the indoor unit will not be used for 1 month or more, turn on FAN operation for half a day to dry the internal parts thoroughly.



Turn off the indoor unit and disconnect from its power source.



Clean all filters and replace if necessary.



Remove the batteries from the remote control.

### MAINTENANCE - INSPECTION STANDARD CHECKLIST



Check for damaged wires.

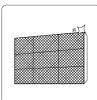

Clean all filters and replace if necessary.



Check for leaks.

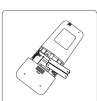

Replace batteries if needed.



Make sure nothing is block all air inlets and outlets.



## OPERATION TIPS

The following events may occur during normal operation:

### 1. Protection of the air conditioner.

#### Compressor protection

To prevent damages to the compressor, the compressor will not restart during the protection circuit for about 3 minutes after sudden off operation.

#### Defrosting

- Frost may be generated on the outdoor unit during heat cycle when outdoor temperature is low and humidity is high resulting in lower heating efficiency of the air conditioner.
- For frost protection, a microcomputer-controlled automatic defrost function is equipped in this air conditioner. If frost forms, the air conditioner will temporarily stop, and start defrosting automatically. The defrost indicator light on the indoor unit blinks during this operation.
- When unit is running on Defrost mode, the air conditioner will stop heating operation and start defrosting automatically.
- The time to defrost may vary from 4 to 10 minutes according to the outdoor temperature and the amount of frost built up on the outdoor unit.

### 2. Mist or steam from the indoor unit

- Mist or steam may be generated due to a sudden and large temperature difference between air inlet and air outlet in COOL or DRY mode. This is common when the relative humidity is high.
- Mist or steam may be generated due to moisture generated from defrosting process in HEAT mode after defrosting.

### 3. Noise of the air conditioner

- Air conditioners may make sounds that are not familiar to you. The sounds listed below are normal.
- The compressor may make a pulsating or high-pitched sound.
- Refrigerant flowing may make a gurgling or low hissing sound.
- Fan sound may come from indoor unit.
- In Heat mode, a sizzling sound produced by the automatic defrosting operation may be heard.

### 4. Dusty air output

- This is a normal condition when the air conditioner has not been used for a long time or during first use of the unit.

### 5. Smell coming from the unit

- This is caused by the smell from the interior, such as furniture, building material or cigarette smoke into the air conditioner.

### 6. The air conditioner turns to FAN only mode from COOL or HEAT mode.

- When indoor temperature reaches the set temperature, the compressor will stop automatically and the air conditioner runs in FAN only mode.
- The compressor will start again when the indoor temperature rises above the set temperature in Cool mode or drops below the set temperature in Heat mode.

## OPERATION TIPS

### 7. Dripping water

Dripping water may generate on the surface of the indoor unit when cooling in a high relative humidity (relative humidity higher than 80%). Adjust the horizontal louver to the maximum air outlet position and select HIGH fan speed.

### 8. Heating mode

The air conditioner draws in heat from the outdoor unit and releases it via the indoor unit during heating operation. When the outdoor temperature falls, heat drawn in by the air conditioner decreases accordingly. At the same time, heat loading of the air conditioner increases due to larger difference between indoor and outdoor temperature. If a comfortable temperature can't be achieved by the air conditioner, we suggest you use a supplementary heating device.

### 9. Malfunctions caused by other devices

Lightning or wireless radio transmitter operating nearby may cause the unit to malfunction. If you encounter such a malfunction, restart the unit or turn off and restart the circuit breaker.

## TROUBLESHOOTING

### SAFETY PRECAUTIONS

If ANY of the following conditions occurs, turn off your unit immediately. **Please do not attempt to fix these problems yourself. Contact an authorized service provider immediately.**

- The power cord is damaged or abnormally warm
- The unit emits burning odor
- The unit emits loud or abnormal sounds
- A power fuse blows or the circuit breaker frequently trips
- Water or other objects fall into or out of the unit

The following problems are not a malfunction and in most situations will not require repairs.

Issue	Possible Causes
Unit does not turn on when pressing ON/OFF button	<ul style="list-style-type: none"> <li>• The unit has a 3-minute protection feature that prevents the unit from overloading. The unit cannot be restarted within three minutes of being turned off.</li> <li>• Check the plug fuse.</li> <li>• Timer is set.</li> </ul>
The unit changes from COOL/HEAT mode to FAN mode	<ul style="list-style-type: none"> <li>• The unit may change its setting to prevent frost from forming on the unit. Once the temperature increases, the unit will start operating in the previously selected mode again.</li> <li>• The set temperature has been reached, at which point the unit turns off the compressor. The unit will continue operating when the temperature fluctuates again.</li> </ul>
The indoor unit emits white mist	<ul style="list-style-type: none"> <li>• In humid regions, a large temperature difference between the room's air and the conditioned air can cause white mist.</li> </ul>
Water drops from the indoor unit	<ul style="list-style-type: none"> <li>• Dripping water may generate on the surface of the indoor unit when cooling in a relatively high humidity (RH more than 80%). Adjust the horizontal louver to the maximum air outlet position and select HIGH fan speed.</li> </ul>
Both the indoor and outdoor units emit white mist	<ul style="list-style-type: none"> <li>• When the unit restarts in HEAT mode after defrosting, white mist may be emitted due to moisture generated from the defrosting process.</li> </ul>
The indoor unit makes noises	<ul style="list-style-type: none"> <li>• A rushing air sound may occur when the louver resets its position.</li> <li>• A squeaking sound may occur after running the unit in HEAT mode due to expansion and contraction of the unit's plastic parts.</li> </ul>
Both the indoor unit and outdoor unit make noises	<ul style="list-style-type: none"> <li>• Low hissing sound during operation: This is normal and is caused by refrigerant gas flowing through both indoor and outdoor units.</li> <li>• Low hissing sound when the system starts, has just stopped running, or is defrosting: This noise is normal and is caused by the refrigerant gas stopping or changing direction.</li> <li>• Squeaking sound: Normal expansion and contraction of plastic and metal parts caused by temperature changes during operation can cause squeaking noises.</li> </ul>
The outdoor unit makes noises	<ul style="list-style-type: none"> <li>• The unit will make different sounds based on its current operating mode.</li> </ul>
Dust is emitted from either the indoor or outdoor unit	<ul style="list-style-type: none"> <li>• The unit may accumulate dust during extended periods of non-use, which will be emitted when the unit is turned on. This can be mitigated by covering the unit during long periods of inactivity.</li> </ul>
The unit emits a bad odor	<ul style="list-style-type: none"> <li>• The unit may absorb odors from the environment (such as furniture, cooking, cigarettes, etc.) which will be emitted during operations.</li> <li>• The unit's filters have become moldy and should be cleaned.</li> </ul>
The fan of the outdoor unit does not operate	<ul style="list-style-type: none"> <li>• During operation, the fan speed is controlled to optimize product operation.</li> </ul>
Operation is erratic, unpredictable, or unit is unresponsive	<p>Interference from cell phone towers and remote boosters may cause the unit to malfunction. In this case, try the following:</p> <ul style="list-style-type: none"> <li>• Disconnect the power, then reconnect.</li> <li>• Press ON/OFF button on remote control to restart operation.</li> </ul>

## TROUBLESHOOTING

Issue	Possible Causes	
Poor cooling performance	Temperature setting may be higher than ambient room temperature	<ul style="list-style-type: none"> <li>• Lower the temperature setting</li> </ul>
	The heat exchanger on the indoor or outdoor unit is dirty	<ul style="list-style-type: none"> <li>• Clean the affected heat exchanger</li> </ul>
	The air filter is dirty	<ul style="list-style-type: none"> <li>• Remove the filter and clean it according to instructions</li> </ul>
	The air inlet or outlet of either unit is blocked	<ul style="list-style-type: none"> <li>• Turn the unit off, remove the obstruction and turn it back on</li> </ul>
	Doors and windows are open	<ul style="list-style-type: none"> <li>• Make sure that all doors and windows are closed while operating the unit</li> </ul>
	Excessive heat is generated by sunlight	<ul style="list-style-type: none"> <li>• Close windows and curtains during periods of high heat or bright sunshine</li> </ul>
	Too many sources of heat in the room (people, computers, electronics, etc.)	<ul style="list-style-type: none"> <li>• Reduce amount of heat sources</li> </ul>
	Low refrigerant due to leak or long-term use	<ul style="list-style-type: none"> <li>• Check for leaks, re-seal if necessary and top off refrigerant; contact an authorized service provider</li> </ul>
	SILENCE function is activated	<ul style="list-style-type: none"> <li>• SILENCE function can lower product performance by reducing operating frequency. Turn off SILENCE function.</li> </ul>
The unit is not working	Power failure	<ul style="list-style-type: none"> <li>• Wait for the power to be restored</li> </ul>
	The power is turned off	<ul style="list-style-type: none"> <li>• Turn on the power</li> </ul>
	The fuse is burned out	<ul style="list-style-type: none"> <li>• Replace the fuse</li> </ul>
	Remote control batteries are dead	<ul style="list-style-type: none"> <li>• Replace batteries</li> </ul>
	The unit's 3-minute protection has been activated	<ul style="list-style-type: none"> <li>• Wait three minutes after restarting the unit</li> </ul>
	Timer is activated	<ul style="list-style-type: none"> <li>• Turn timer off</li> </ul>
The unit starts and stops frequently	There's too much or too little refrigerant in the system	<ul style="list-style-type: none"> <li>• Check for leaks and recharge the system with refrigerant; contact an authorized service provider</li> </ul>
	Incompressible gas or moisture has entered the system	<ul style="list-style-type: none"> <li>• Evacuate and recharge the system with refrigerant; contact an authorized service provider</li> </ul>
	The compressor is broken	<ul style="list-style-type: none"> <li>• Replace the compressor; contact an authorized service provider</li> </ul>
	The voltage is too high or too low	<ul style="list-style-type: none"> <li>• Install a manostat to regulate the voltage; contact an authorized service provider</li> </ul>
Poor heating performance	The outdoor temperature is extremely low	<ul style="list-style-type: none"> <li>• Use auxiliary heating device</li> </ul>
	Cold air is entering through doors and windows	<ul style="list-style-type: none"> <li>• Make sure that all doors and windows are closed during use</li> </ul>
	Low refrigerant due to leak or long-term use	<ul style="list-style-type: none"> <li>• Check for leaks, re-seal if needed and top off refrigerant; contact an authorized service provider</li> </ul>
<p>Indicator lamps continue flashing</p> <p>Error code appears in the window display of indoor unit:</p> <ul style="list-style-type: none"> <li>• E0, E1, E2...</li> <li>• P1, P2, P3...</li> <li>• F1, F2, F3...</li> </ul>	<p>The unit may stop operation or continue to run safely. If the indicator lamps continue to flash or error codes appear, wait for about 10 minutes. The problem may resolve itself. If not, disconnect the power, then connect it again. Turn the unit on.</p> <p>If the problem persists, disconnect the power and contact an authorized service provider.</p>	

# ONE YEAR LIMITED PARTS WARRANTY & THREE YEAR WARRANTY ON COMPRESSOR

This WHYNTER Mini Split Inverter Ductless Air Conditioner System includes a one year limited parts warranty and additional two year compressor warranty.

The system is warranted to the original owner while the product is still installed in the original place of the first installation. It must be purchased from an authorized Whynter dealer and installed by a certified installer within the 48 U.S. continental states, for one year from the original purchase date against part defects in material and workmanship under normal residential usage.

To make a warranty claim on your WHYNTER Mini Split Inverter Ductless Air Conditioner system, the owner must contact the installer to diagnose and determine the cause of the issue. Upon the installer's determination that the issue is caused by a defect covered under this warranty, the installer may contact Whynter's Customer Support team with the following documents and information: 1) Proof of purchase, 2) Proof of installation by a licensed installer or provider, 3) The system's serial number, 4) The installer's service report, indicating the cause of the issue covered under the warranty, 5) Whynter may request additional documentation or photos prior to processing the warranty claim.

Under this warranty, Whynter will replace any parts found defective by the installer with new or remanufactured parts or exchange the parts with a new, refurbished, or remanufactured parts at our discretion within one year from the date of purchase. All defective parts covered by this warranty will be installed and repaired by the installer or provider. Shipping costs for any parts are the responsibility of the owner. Return of the original or defective parts to Whynter may be requested in some instances before replacement parts can be provided.

The compressor of the system is warranted for an additional two years after the one year limited parts warranty expires from the date of purchase. Should the compressor prove defective in materials or workmanship, under normal residential usage at the installer's determination, during the two years following the initial one year parts warranty, Whynter will provide a replacement.

Cost of labor, materials or other costs for supplies or materials purchased for the replacement of defective parts are the responsibility of the owner. Other costs, such as diagnosis, servicing, repair, replacement, installation, removal, transportation or shipping, etc. are NOT covered by this warranty. This warranty is not transferable. After the expiration of the warranty, all costs will be the responsibility of the original owner.

## **THIS WARRANTY DOES NOT COVER:**

- Acts of God or environmental conditions, such as fire, flood, hurricanes, earthquakes and tornadoes, etc.
- Improper power supply such as power surge, low voltage, defective household wiring or inadequate fuses.
- Use in commercial or industrial applications.
- Damage, accidental or otherwise, to the product while in the possession of a consumer not caused by a defect in material or workmanship.
- Damage caused by consumer misuse, tampering, lack of maintenance or failure to follow the care and special handling provisions in the instructions.
- Damage to the finish of the case, or other appearance parts caused by wear.
- Damage caused by repairs or alterations to the product by unqualified persons, installation by unlicensed providers, installers or contractors, installations that do not take place within 30 days of purchase.
- Installation costs, removal, repairs, diagnosis and service fees.
- Under-sizing, over-sizing, improper matching or selection of equipment for the required application.
- Products sold AS IS or from an unauthorized reseller.
- Products that have had their serial numbers removed or defaced.

## **DISCLAIMER OF IMPLIED WARRANTIES; LIMITATION OF REMEDIES**

*CUSTOMER'S SOLE AND EXCLUSIVE REMEDY UNDER THIS LIMITED WARRANTY SHALL BE REPLACEMENT PARTS AS PROVIDED HEREIN. CLAIMS BASED ON IMPLIED WARRANTIES, INCLUDING WARRANTIES OF MERCHANTABILITY OR FITNESS FOR A PARTICULAR PURPOSE, ARE LIMITED TO ONE YEAR OR THE SHORTEST PERIOD ALLOWED BY LAW, BUT NOT LESS THAN ONE YEAR. WHYNTER SHALL NOT BE LIABLE FOR CONSEQUENTIAL OR INCIDENTAL DAMAGES SUCH AS PROPERTY DAMAGE AND INCIDENTAL EXPENSES RESULTING FROM ANY BREACH OF THIS WRITTEN LIMITED WARRANTY OR ANY IMPLIED WARRANTY. SOME STATES AND PROVINCES DO NOT ALLOW THE EXCLUSION OR LIMITATION OF INCIDENTAL OR CONSEQUENTIAL DAMAGES, OR LIMITATIONS ON THE DURATION OF IMPLIED WARRANTIES, SO THESE LIMITATIONS OR EXCLUSIONS MAY NOT APPLY TO YOU. THIS WRITTEN WARRANTY GIVES YOU SPECIFIC LEGAL RIGHTS. YOU MAY ALSO HAVE OTHER RIGHTS THAT VARY FROM STATE TO STATE.*

The warranty, product contents and specifications are subject to change at any time without notice; please refer to [www.whynter.com](http://www.whynter.com) for the most current information.

To register your warranty, please visit [www.whynter.com](http://www.whynter.com) and fill out the online Warranty Registration form. Please be sure to include a copy of your purchase invoice.

To obtain service or information, contact Whynter LLC via email at [support@whynter.com](mailto:support@whynter.com) or call 866-WHYNTER (866-949-6837).